

# Energy Efficient Cluster-based Routing using Hybrid Approach of Fuzzy and Ida-Star for Wireless Sensor Networks

Mohaideen Pitchai K (✉ [mohaideen1981@gmail.com](mailto:mohaideen1981@gmail.com))

National Engineering College <https://orcid.org/0000-0003-4058-7718>

---

## Research Article

**Keywords:** Clustering, Routing, Sensor Networks, Fuzzy Logic, Energy Efficiency

**Posted Date:** June 29th, 2021

**DOI:** <https://doi.org/10.21203/rs.3.rs-589671/v1>

**License:**  This work is licensed under a Creative Commons Attribution 4.0 International License.

[Read Full License](#)

---

# **ENERGY EFFICIENT CLUSTER-BASED ROUTING USING HYBRID APPROACH OF FUZZY AND IDA-STAR FOR WIRELESS SENSOR NETWORKS**

**MOHAIDEEN PITCHAI K**

ASSOCIATE PROFESSOR (SG), DEPARTMENT OF COMPUTER SCIENCE AND ENGINEERING,  
NATIONAL ENGINEERING COLLEGE, KOVILPATTI-628503, TAMILNADU, INDIA

E-MAIL: mohaideen1981@gmail.com

## **ABSTRACT**

Appropriate cluster head selection can significantly reduce energy consumption and enhance the lifetime of the WSN. The choice of cluster heads, which is a pivotal step in the cluster-based algorithm, can seriously influence the performance of the clustering algorithm. Under normal circumstances, whether a node can be a cluster head or not depends not only on its energy level but also on the other factors such as energy consumption, channel lost, neighbor density, etc. In this sense, the selection of the cluster head can be regarded as a multiple criteria decision-making issue. This paper presents an Energy efficient Cluster Head selection using Fuzzy Logic (ECHFL) protocol, which combines the approaches of the fuzzy and IDA-star algorithm. This protocol selects the appropriate cluster head by using fuzzy inference rules. It uses three parametric descriptors such as residual energy, expected residual energy, and node centrality for the cluster formation and cluster head selection processes. These parameters contribute mainly for avoiding over-dissipation of energy in the network by selecting the suitable cluster head for the network. This protocol shows how fuzzy logic can be used in the cluster formation process to distribute the tasks and energy consumption over all the nodes. As a summary, the proposed protocol gives good performance results in comparison with the other protocols.

**Keywords:** Clustering, Routing, Sensor Networks, Fuzzy Logic, Energy Efficiency

## 1 INTRODUCTION

The lifetime of sensor networks depends on the nodes energy level which is an essential factor for efficient data gathering. The energy consumption of nodes should be balanced during the routing process. The objective of any routing algorithm is to minimize the total energy dissipation of the network with the constraint of non-uniform energy depletion of nodes. The quick depletion of an energy level of critical nodes causes a network partition which affects the data collection process from the environment. Also, it leads to change in the lifetime of the network. These issues create many challenges in the design of sensor networks. Hence the objective of any routing algorithm must balance the energy consumption of nodes in the network. The algorithm should minimize the energy consumption of the network by adjusting the energy consumption of individual nodes in the network. The optimization of energy efficiency and energy balancing simultaneously is a hard problem. However, an optimal solution should be obtained. (Haifeng Jiang et al. 2013).

Sensor networks based on clustering architecture have various advantages. It minimizes the energy consumption and prolonging the network lifetime. Also, it supports efficient data aggregation, increasing the scalability, fault-tolerant data transmission, and collaborative signal processing. Compared to other nodes in a cluster, cluster head consumes more energy. This is due to its additional process of compressing and aggregating the data collected by each sensor node and then transmitting to the base station. Hence it is essential to optimize the energy consumption level of cluster heads by allowing it to communicate with the base station in a multi-hop fashion. By finding an appropriate cluster head selection mechanism, the energy consumption of cluster heads can be reduced and also will enhance the lifetime of the network. In any clustering algorithm, the selection of cluster head is playing an important role which can influence the performance of those algorithms. A node cannot be chosen as cluster head based on the energy level but also considers other parameters like neighbor density, channel

bandwidth, communication radius, etc. Hence the cluster head selection process is a decision-making process which should consider many parameters for a node to become a cluster head. (Teng Gao et al. 2012).

## 2 PREVIOUS WORKS

LEACH-B (LEACH-Balanced) is a popular energy efficient clustering protocol in sensor networks. It overcomes the drawback of LEACH like fluctuations in finding some cluster heads and the residual energy level of nodes. Here a new round of selection of cluster head is introduced which considers the residual energy level of nodes. It selects a random number between 0 and one like as LEACH protocol. Then it calculates the value of threshold by using the following formula.

$$T(n) = \begin{cases} \frac{p}{1 - p(r \bmod \frac{1}{p})} & \text{if } n \in G \\ 0 & \text{Otherwise} \end{cases} \quad (1)$$

As per the values of node's residual energy, the candidate cluster heads are ordered in decreasing order. Finally  $(n \cdot p)$  cluster heads are considered. The remaining cluster heads are resumed as a normal node. Thus the generation of an optimal number of cluster heads is guaranteed. LEACH-B protocol achieves the balanced behaviors among energy consumption and generation of an optimal number of cluster heads which prolongs the lifetime of the network than basic LEACH protocol.

The protocol FEAR (Fuzzy Energy Aware tree-based Routing) increases the lifetime of the network by restricting the energy consumption of nodes. Also, it enhances the existing tree structured routing protocols. It ranks the nodes in the network by using a fuzzy based mechanism. The mechanism ensures that each node should correctly associate with its suitable neighbor nodes during the tree construction phase. FEAR gives a promising solution for routing and also it prolongs the lifetime of the network even in

the case of network failure. A list of neighbor nodes of each node is maintained to use the links of neighbors. It has various phases like sink-rooted tree construction, message transmission and node/link failure problem recovery. It decreases the power consumption of nodes up to 70% and reduces the control overhead up to 70% as compared with other related works. (Iman Al-Momani & Maha Saadeh 2011)

Hakan Bagci & Adnan Yazici (2013) addressed the hot spots problem by decreasing the workload of cluster heads in intra-cluster which has low remaining energy level or which is very close to the base station. They proposed an algorithm named Fuzzy Energy Aware Unequal Clustering Algorithm (EAUCF) which uses fuzzy logic to estimate the radius of each cluster head. The results of EAUCF are compared with LEACH, Cluster-Head Election Mechanism using Fuzzy Logic and Energy-Efficient Unequal Clustering. It performs better than other algorithms regarding various metrics like energy efficiency, number of nodes alive and throughput. The authors concluded that EAUCF is a stable energy efficient mechanism that can be better applicable in most WSN application environments.

Ying Zhang et al. (2017) proposed an energy efficient distributed clustering algorithm which uses the fuzzy approach with non-uniform distribution (EEDCF) mechanism. The authors considered nodes' remaining energy level, nodes' degree and neighbor nodes' residual energy as input parameters for cluster head selection. The Takagi, Sugeno, and Kang (TSK) fuzzy model is used in their inference system to make the quantitative analysis more reasonable. Using the TSK inference system, the probability of a node becomes a cluster head is calculated in a distributed manner. The performance results show that EEDCF outperforms as compared with other methods in various aspects like data transmission, energy consumption and lifetime of networks.

### **3 THE PROPOSED SCHEME**

In wireless sensor networks, the network lifetime is improved by choosing an appropriate cluster head, and the selection needs an efficient algorithm to reduce the energy consumption. The proposed ECHFL(Energy efficient Cluster Head selection using Fuzzy Logic) algorithm efficiently increases the lifetime of the network, and its methodology is divided into three phases, namely Cluster Formation, Cluster Head Selection, and Data Transmission.

### 3.1 Cluster Formation

In the proposed system, cluster formation is done with the help of Fuzzy C Means (FCM) clustering algorithm. FCM is a data clustering technique wherein each data point belongs to a cluster to some degree that is specified by a membership grade. It provides a method that shows how to group data points that populate some multidimensional space into a specific number of different clusters. In FCM algorithm, the input parameters to be given are data points  $(x, y)$  that are the position of sensor nodes and the number of clusters  $C$ . The output obtained from the algorithm will be the formation of the number of clusters. The FCM algorithm consists of the following steps:

**Step 1:** The position of the sensor nodes and the number of clusters  $C$  are given as input to this algorithm, where  $2 \leq C \leq N$ . The position of the nodes can be given by loading a dataset which consists of different data points.

**Step 2:** Initialize the membership matrix  $U^{(t)}$  by using the following membership function  $(\mu_{ij})$ .

$$\mu_{ij} = \frac{1}{\sum_{k=1}^c \left( \frac{d_{ij}}{d_{ik}} \right)^{\frac{2}{m-1}}} \quad (2)$$

Where  $d_{ij}$  is the distance between  $i^{\text{th}}$  data and  $j^{\text{th}}$  cluster center. The value  $d_{ij}$  can be calculated as  $\|x_i - y_i\|$  and  $\|x_j - y_j\|$ .  $m$  is the fuzziness exponent with its initial value 2.  $\mu_{ij}$  is the value of the membership function of the  $i^{\text{th}}$  pattern belonging to the  $j^{\text{th}}$  cluster.

**Step 3:** After initializing the membership matrix ( $U^{(t)}$ ), compute the new center matrix using the following formula

$$W_j^t = \frac{\sum_{i=1}^N (\mu_{ij}^{t-1})^m x_i}{\sum_{i=1}^N (\mu_{ij}^{t-1})^m} \quad i, j = 1, 2, \dots, C \quad (3)$$

where  $W_j$  is a function which can position the center of the clusters to be formed.

**Step 4:** Compute the new membership matrix ( $U^{(t+1)}$ ) by using Equation (6.1) for the newly formed clusters

**Step 5:** Repeat the steps 2 to 4 until  $\|U^{(t+1)} - U^{(t)}\| < \varepsilon$  where  $\varepsilon$  is a fixed threshold value and then record the cluster centers. The FCM algorithm is shown in Figure 1.

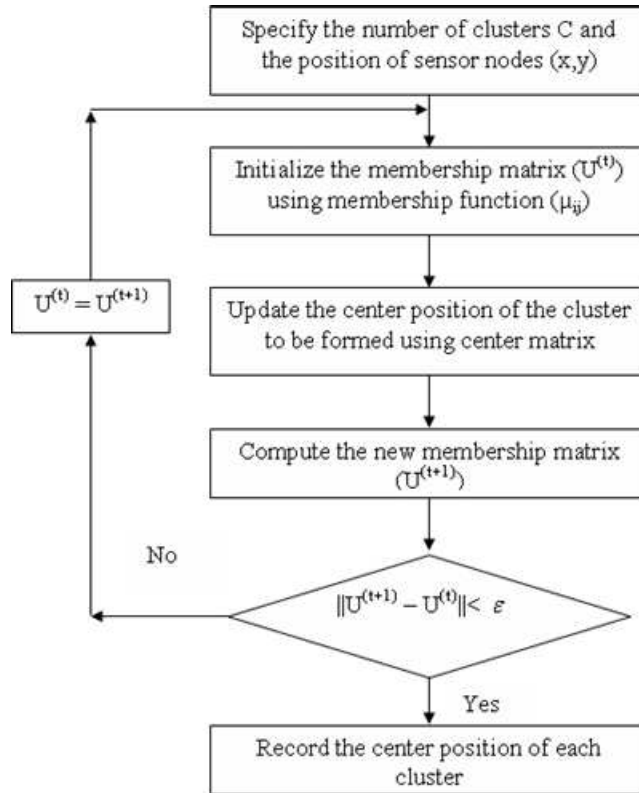
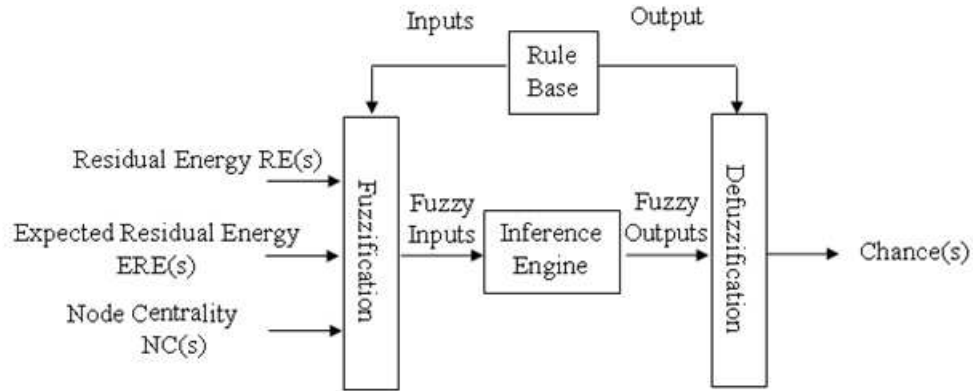

**Figure 1 FCM cluster formation**

### 3.2 Cluster Head Selection

After the cluster formation, an appropriate cluster head is to be selected for each cluster. In this regard, the fuzzy approach is used for cluster head selection. The fuzzy approach is used to calculate the value of the fitness function (chance of node  $S$ ) that depends on the residual energy  $RE(S)$ , the expected residual energy  $ERE(S)$  and the node centrality  $NC(S)$ . Figure 2 shows the fuzzy approach with three input variables  $RE(S)$ ,  $ERE(S)$  and  $NC(S)$  with one output chance( $S$ ). The universal of disclosure of the variables  $RE$ ,  $ERE$ ,  $NC$  and chance are  $[0..1]$ . ECHFL uses three membership functions for each input and seven membership functions for the output variable as shown in Figure 3.





**Figure 2 Fuzzy Structure with three inputs and one output**

It is based on three descriptors like residual energy, expected residual energy and node centrality. Residual Energy (RE) is the overall energy level available in each sensor node. Expected Residual Energy (ERE) explains the amount of energy consumed during routing path establishment. Expected Residual Energy is the subtracted value of residual energy and energy consumption. Node Centrality (NC) is a value that classifies the nodes based on how central the node is to the cluster. In the proposed model, three attributes of each Cluster Head (residual energy, expected residual energy, and node centrality) are given as an input to the Fuzzy Inference System.

**Table 1 Fuzzy Rules**

Rule	Antecedent (IF)			Consequent (THEN)
	RE	ERE	NC	Chance
Rule 1	Low	Excellent	Close	Small
Rule 2	Low	Excellent	Adequate	Rather Small
Rule 3	Low	Excellent	Far	Very Small
Rule 4	Low	Good	Close	Small
Rule 5	Low	Good	Adequate	Rather Small
Rule 6	Low	Good	Far	Very Small
Rule 7	Low	Poor	Close	Small
Rule 8	Low	Poor	Adequate	Rather Small
Rule 9	Low	Poor	Far	Very Small
Rule 10	Medium	Excellent	Close	Rather Large
Rule 11	Medium	Excellent	Adequate	Medium

Rule 12	Medium	Excellent	Far	Small
Rule 13	Medium	Good	Close	Rather Large
Rule 14	Medium	Good	Adequate	Medium
Rule 15	Medium	Good	Far	Small
Rule 16	Medium	Poor	Close	Rather Large
Rule 17	Medium	Poor	Adequate	Medium
Rule 18	Medium	Poor	Far	Small
Rule 19	High	Excellent	Close	Very Large
Rule 20	High	Excellent	Adequate	Large
Rule 21	High	Excellent	Far	Rather Large
Rule 22	High	Good	Close	Very Large
Rule 23	High	Good	Adequate	Large
Rule 24	High	Good	Far	Rather Large
Rule 25	High	Poor	Close	Very Large
Rule 26	High	Poor	Adequate	Large
Rule 27	High	Poor	Far	Rather Large

These attributes are chosen as input parameters because they are the factors directly influencing energy dissipation and network lifetime. The proposed system defines three input linguistic variables for representing each parameter into three levels: low, medium and high for residual energy; and close, adequate and far for the node centrality; and excellent, good and poor for expected residual energy. The output linguistic variable of a chance to become a cluster head uses seven linguistic variables which include small, very small, rather small, medium, rather large, large and very large. The proposed system uses 27 rules for selecting the chance of a node to become a cluster head. Table 1 shows the Fuzzy rules used in ECHFL.

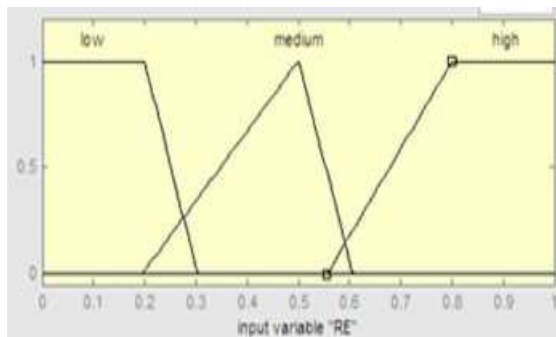

Input -1

Residual Energy  
RE(S)

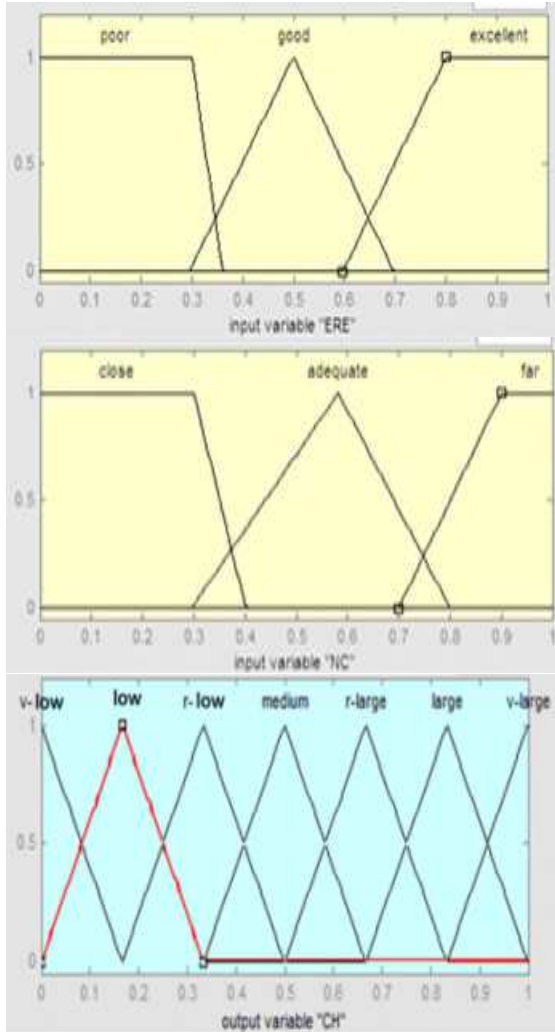

Input - 2

Expected Residual  
Energy  
ERE(S)

Input - 3

Node Centrality  
NC(S)

Output

Chance (S) to  
become a Cluster  
Head.

**Figure 3 Membership Graph for three inputs and one output**

Triangular and trapezoidal membership functions are used for fuzzification method. Defuzzification converts the fuzzy value to a crisp number, and the way used here for defuzzification is center of gravity method given by

$$Chance(S) = \frac{\sum_{k=1}^n U_k * C_k}{\sum_{k=1}^n U_k} \quad (4)$$

Where  $U_k$  is the output of rule base  $k$ , and  $C_k$  is the center of the output membership function for the  $n$  rule base number. In this way, the chance to become a cluster head can

be calculated for all the nodes within the cluster. The node that has the highest chance value can be selected as cluster head as shown in Figure 4.

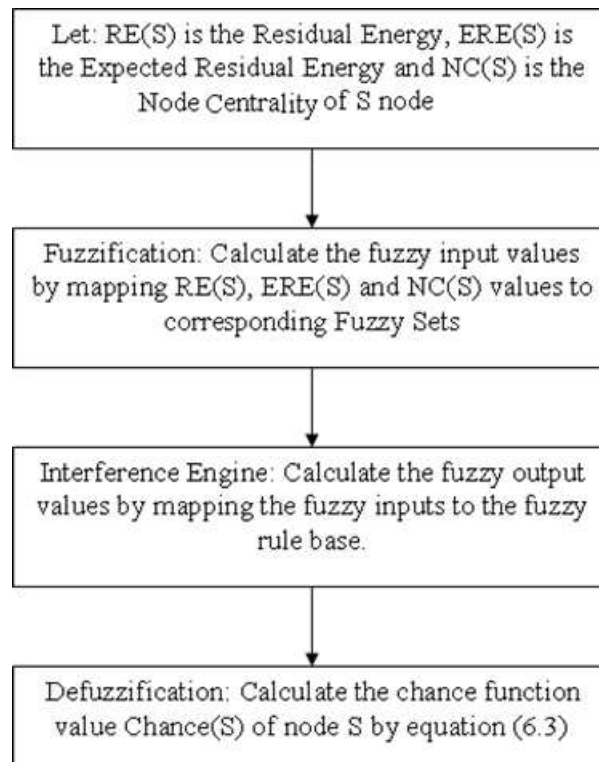

**Figure 4 Cluster head selection using the fuzzy approach**

### 3.3 Data Transmission

After the cluster head selection, the data transmission can be done by using the IDA-Star algorithm. This algorithm is a widely used graphic searching algorithm. It is also a highly efficient heuristic algorithm used in finding optimal cost between source and destination. It can be used to reduce memory usage, and it also supports to prolong the network lifetime since it reduces the amount of memory needed for transmission. There are two different lists are maintained in IDA-Star algorithm which is OPEN List and a CLOSE List. The OPEN list can be viewed as a priority queue, and it contains a sequence of nodes. It selects the next node which has the least value of the evaluation function. The CLOSE list contains a sequence OPEN list initially. Then it checks whether

it is the target node. If so, the algorithm is stopped. Otherwise, the value of the evaluation function of all its neighbor nodes is calculated. Also, those nodes are added in the OPEN List. A solution will be obtained after the completion of the IDA star algorithm. If the solution is not obtained, the IDA star algorithm chooses the low-cost path as the final path. The IDA star algorithm depends on the value generated from the cost evaluation function. The steps followed in the IDA star algorithm are

**Step 1:** Put the source node  $src$ .  $Cost(src)$  is added to the OPEN list. Let the CLOSE list be empty.

**Step 2:** If the OPEN list is empty, set the initial threshold  $(t)$ .

**Step 3:** Otherwise, remove the first node  $n$  from OPEN list and add it to CLOSE list.

**Step 4:** If  $n$  is destination node, SUCCEED and return the path from the source node to  $n$ .

**Step 5:** If the node  $n$  is not the destination, repeat Step 2.

**Step 6:** Remove  $n$  from OPEN list and check whether it lies within the threshold level. If so, insert the child  $n'$  of  $n$  into an OPEN list so that  $f(n') \leq t$ .

**Step 7:** Repeat from Step 2 until the optimal path is established.

In this routing method, the base station prepares the routing schedule and broadcasts it to each node. The IDA-Star algorithm which is used to find the optimal route from the node to the base station is applied to each node. The IDA-Star algorithm creates a tree structure to search optimal routing path from a given node to the base station. The tree node is explored based on distance heuristic evaluation function  $f(n)$  which determines the order in which the search visits nodes in the tree. This heuristic evaluation function is a sum of two functions as follows.

$$f_{\text{cost}}(n) = g_{\text{srccost}}(n) + h_{\text{descost}}(n) \quad (5)$$

Where  $f_{\text{cost}}(n)$  is the total cost of the path,  $g_{\text{srccost}}(n)$  is the actual cost from the source node to current node  $n$ , and  $h_{\text{descost}}(n)$  is the estimated cost of the optimal path from the current node  $n$  to the target node (destination node), which depends on the heuristic information of the problem area. In the proposed scheme, the value of  $g(n)$  function is equal to the node cost of node  $n$ . The intention is to forward data packets from cluster head to the next neighbor node which has higher residual energy, higher packet reception rate and distance to the base station. To achieve this, aggregated weight of the mentioned routing parameters is used. The aggregated weight of a next neighbor node is the sum of normalized weights of its routing metrics. It is defined as Equation 6

$$g_{\text{srccost}}(n) = \max \left( \alpha \left( \frac{E_{\text{res}}(n)}{E_{\text{init}}(n)} \right) + \beta \left( \frac{N_r(n)}{N_t(n)} \right) \right) \quad (6)$$

Where  $E_{\text{res}}(n)$  and  $E_{\text{init}}(n)$  are the residual and initial energy of node  $n$  respectively. Also,  $N_t(n)$  and  $N_r(n)$  are the numbers of transmitted and received packets respectively.  $\alpha$  and  $\beta$  are the weight factors whose sum is equal to one. The parameter of node cost is related to the linear combination of two normalized metrics. The first parameter illustrates the residual energy of the next neighboring node  $n$ . This parameter is aimed to ascertain that the sensor nodes' energy consumptions are balanced. The second parameter is the number of received packets in node  $n$ . This metric corresponds with the packet reception rate of the next node. In other words, maximizing this metric is equal to maximizing the packet transmission efficiency. As a result of taking this metric into account, the retransmission of data packets will be prevented which will significantly reduce the amount of energy consumption in the node. The value for  $h_{\text{descost}}(n)$  function can be calculated as follows

$$h_{\text{descost}}(n) = \frac{1}{\text{Min}(hc_{n-to-BS})} \quad (7)$$

Where  $Min(hc_{n-to-BS})$  is the minimum hop count from node n to the base station? To compute the minimum hop count from node n to the base station, the distance between node n and base station ( $D_{n-to-BS}$ ) is calculated via Euclidean distance equation as follows:

$$D_{n-to-BS} = \sqrt{(x_n - x_{BS})^2 + (y_n - y_{BS})^2} \quad (8)$$

Where  $D_{n-to-BS}$  is equal to the Euclidian distance between the node n and base station. Moreover, the hop count from node n to the base station can be calculated as follows:

$$hc_{n-to-BS} = \left( \frac{D_{n-to-BS}}{D_{max}} \right) \quad (9)$$

Where  $D_{max}$  is the maximum transmission radius of the network. Thus, choose the neighbor node n which has the maximum evaluation function  $f_{cost}(n)$ . Figure 5 shows the routing process based on IDA-Star algorithm.

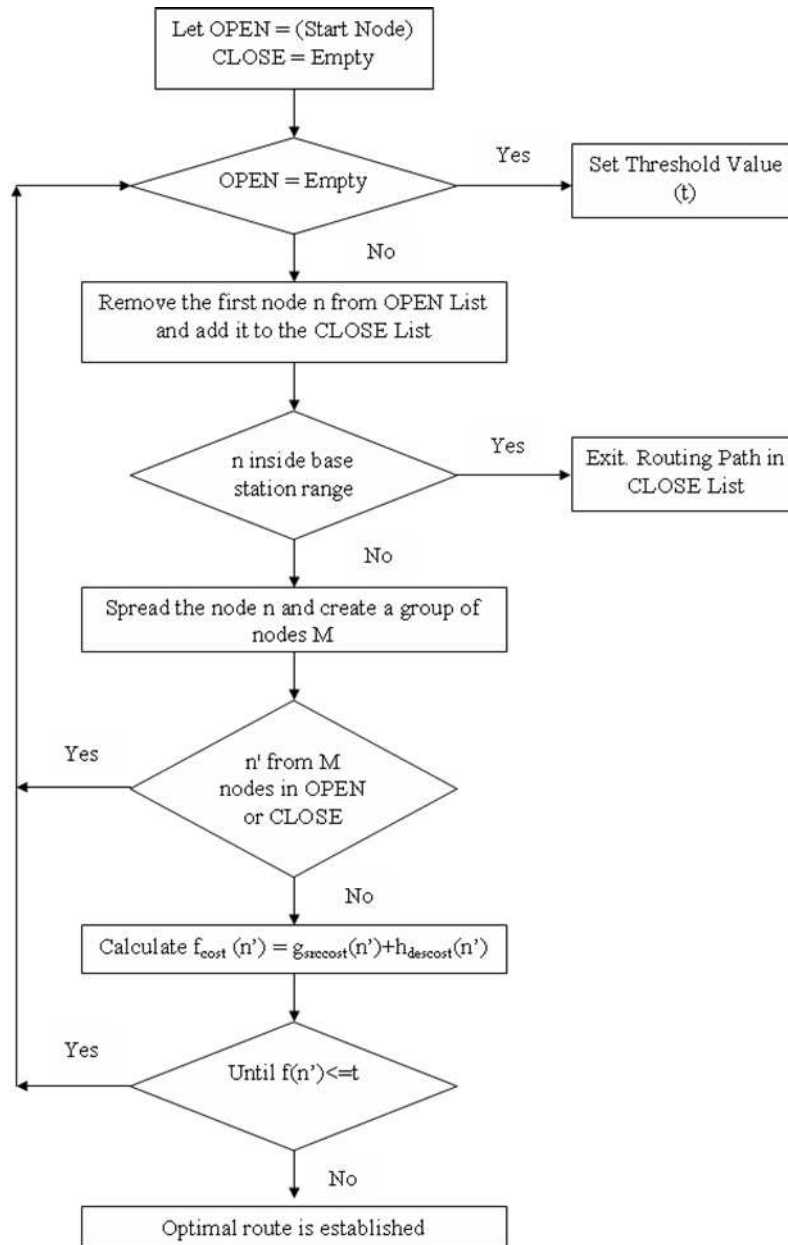

**Figure 5 IDA–Star algorithm for Routing**

## 4 SIMULATION AND RESULTS

### 4.1 Simulation Study

This work is simulated using Matlab 7.10 and NS 2.32. To evaluate the performance of the ECHFL protocol in a realistic scenario, the sensor nodes are deployed



randomly and compared with routing protocols LEACH-B, FEAR and ASEER. The parameter settings of the ECHFL are tabulated in Table 2.

**Table 2 Parameter settings for simulation**

<b>Parameter</b>	<b>value</b>
Number of nodes	50-400
Area of deployment	100x100 m <sup>2</sup>
Initial energy of a node	2 joules
Transmission range	20m
Length of the packet	1000 bits
Base Station Location	(50,150)
Mobility Speed	5-30m/s.
Mobility model	RWP
Energy Consumption Model	First Order Radio Model
Energy consumption for data aggregation	5 nJ/bit/message
Amount of energy needed to transmit one bit of information	50nJ/bit
Amount of energy spent on Amplification in Free Space Propagation	10 pJ/bit/m <sup>2</sup>
Amount of energy spent on Amplification in Multi-Path Propagation	0.0013 pJ/bit/m <sup>4</sup>

## 4.2 Results and Discussion

This section presents the performance results of the designed ECHFL protocol compared with various other existing protocols such as LEACH-B, FEAR and ASEER obtained through simulation. The results are measured in terms of the number of nodes alive, node energy dissipation, end-to-end delay, packet delivery ratio and hop count.

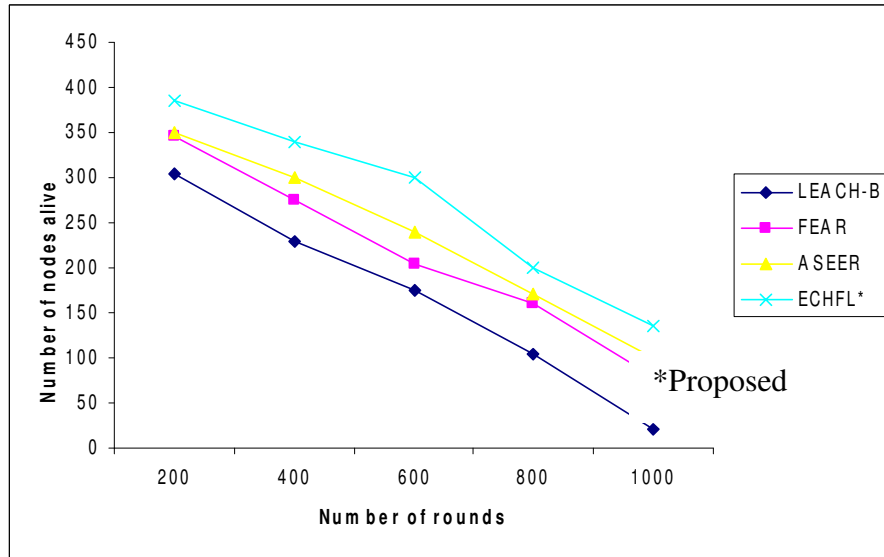

**Figure 6 Network lifetime comparison in terms of alive nodes**

Figure 6 shows the number of alive nodes comparison for all routing protocols with ECHFL. From the simulation results, it is observed that up to 400 rounds nearly 340 nodes were alive in the ECHFL protocol. Even after 1000 rounds, approximately 135 nodes are alive in the ECHFL protocol, since the network lifetime is directly related to the energy dissipation of the nodes. Also, the ECHFL protocol used the residual energy and expected residual energy for cluster head selection among the sensors to avoid draining the battery of any one sensor node in the network. In this way, the energy load of being a cluster head is evenly distributed among the nodes. Hence, the lifetime of the ECHFL protocol is longer than the other protocols. But in the case of different protocols, the number of nodes alive is from 230 to 300 for 400 rounds and from 20 to 100 after 1000 rounds.

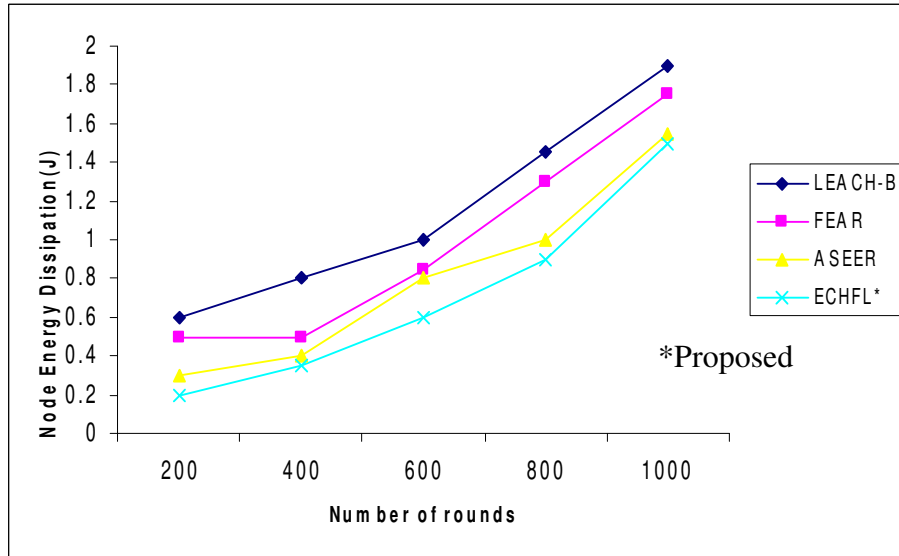

**Figure 7 Comparison of node energy dissipation**

Figure 7 shows the simulation results of node energy dissipation of the LEACH-B, FEAR, and ASEER with the ECHFL protocol. The ECHFL has lower node energy dissipation compared to that of the other protocols. The node energy dissipation of the ECHFL is 0.2 joules for 200 rounds and 1.5 joules after 1000 rounds because ECHFL chooses the next hop nodes which presumably have more residual energy and more packet reception rate. But the other protocols spent more than 0.3 to 0.6 joules for 200 rounds and from 1.6 to 1.9 joules after 1000 rounds since the heuristic function used in IDA-star algorithm depends on the residual energy and distance to the base station.

Figure 8 shows the packet delivery ratio of all the protocols for 200 rounds for static network condition, compared with the ECHFL protocol. It is observed that the delivery ratio of the proposed protocol ECHFL is 65 % for a network size of about 200 nodes. The ASEER protocol also has a good packet delivery ratio of about 62%. For all other protocols, the packet delivery ratio is only between 50% and 55%. For a network size of about 400 nodes, the packet delivery ratio of the ECHFL is also nearly 55%, but for the other protocols, it is only from 26 to 44% because ECHFL uses packet reception rate as one of the factors in heuristic evaluation factor in IDA-star algorithm.

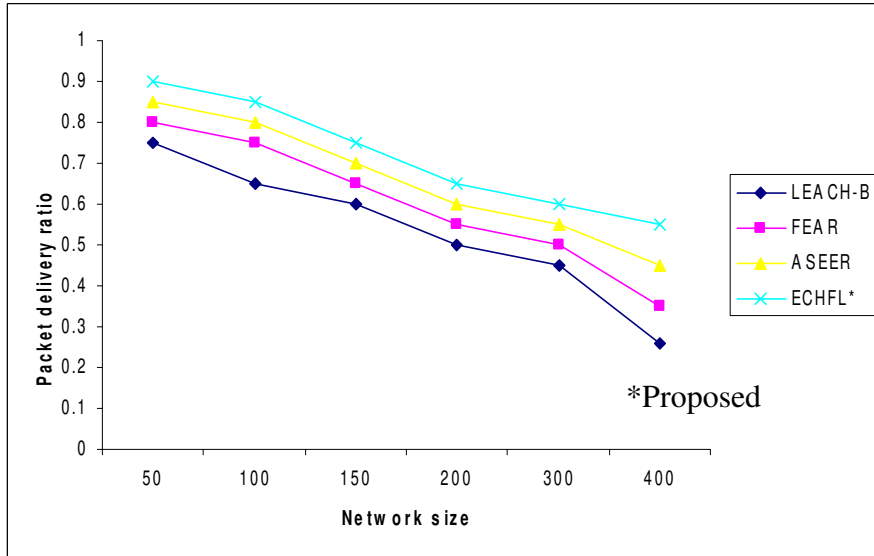

**Figure 8 Packet delivery ratio in static network**

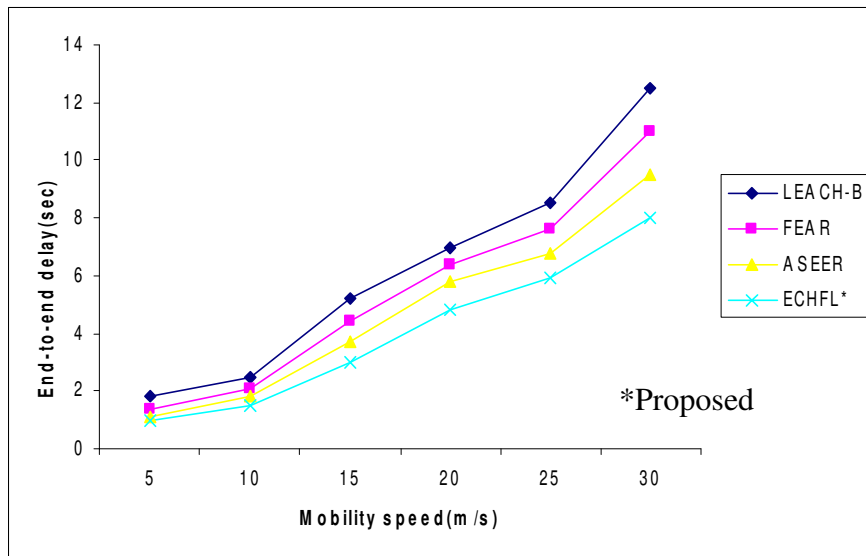

**Figure 9 Comparison of end-to-end delay**

Figure 9 shows the end-to-end delay comparison for different routing protocols. ECHFL protocol exhibits 3s end-to-end delay for nodes having the mobility speed of 15m/s, whereas the other protocols have an end-to-end delay from 3.7s to 5.2s. This is due to the consideration of the distance between the cluster head to the base

station in heuristic evaluation function determination. Also, it is observed that ECHFL has a less end-to-end delay of 5.9s for nodes having the mobility speed of 25m/s. But the protocols FEAR and ASEER have an end-to-end delay of 6.8s and 8.5s respectively. There is a possible delay during the cluster formation and cluster head selection process. But in ECHFL, with the use of the threshold based IDA star algorithm, the delay is reduced. Due to the fixed calculation time irrespective of the nodes in a cluster, the delay is reduced.

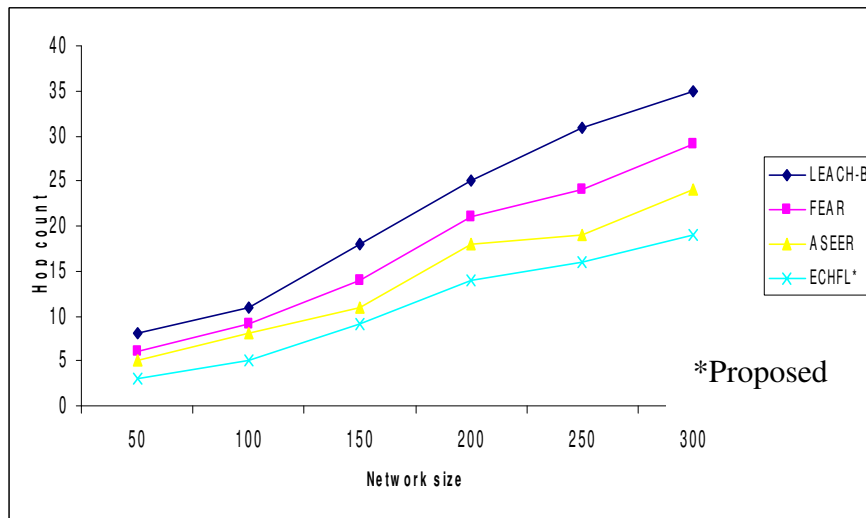

**Figure 10 Hop Count Comparison**

Figure 10 shows the hop count of the different routing protocols. While executing for 100 numbers of nodes, the number of hops for the best route is 5 whereas, for the other protocols, the number of hops is 8, 9 and 11 for LEACH-B, FEAR, and ASEER respectively, due to the optimal selection of the next hop node using IDA-Star algorithm. This leads to the elimination of unsuitable neighbor nodes. As a consequence of this, the hop count is minimum in the ECHFL protocol. Thus the proposed protocol achieves path optimality. The average hop count of ECHFL is 11, but in the case of the other protocols, it is 14, 17 and 21 respectively.

## 5 CONCLUSION

The proposed protocol selects the appropriate cluster head by using fuzzy inference rules. It aims at balancing energy consumption of the whole network and extends the network lifetime by balancing the energy consumption of the cluster heads. The system is simulated by Matlab and NS2 platform, and the simulation results indicate that the energy efficiency and the lifetime of the network are both better than those of the other protocols. Also, the proposed algorithm uses three parametric descriptors such as residual energy, expected residual energy, and node centrality for the cluster formation and cluster head selection process. These parameters contribute mainly for avoiding over dissipation of energy in the network by selecting the suitable cluster head for the network. The proposed system shows how fuzzy logic can be used in the cluster formation process to distribute the tasks and energy consumption over all the nodes. Creating equilibrium and uniformity and increasing network life time is the outcome of using fuzzy logic. The IDA star algorithm provides energy efficient optimal path for data transmission from the source node to the base station through the energy-aware heuristic evaluation function. The future extension of the system will be to adjust the shape of the used parameters or to use different parameters to achieve the additional improvement in the network lifetime and energy consumption of the network.

### DECLARATION:

This proposed work does not receive *funding* from any governmental and non-governmental agencies. The author does not have *conflicts of interest/competing interests* to review and publish the paper in this journal. This work does not use any *data or material (data transparency)*. The *code availability (software application or custom code)* for this work is not applicable.

### DATA AVAILABILITY STATEMENT:

Data sharing not applicable to this article as no datasets were generated or analyzed during the current study.

## REFERENCES

- [1] Wendi Rabiner Heinzelman Anantha Chandrakasan and Hari Balakrishnan, 2000, Energy-Efficient Communication Protocol for Wireless Microsensor Networks, Proceedings of the 33<sup>rd</sup> Hawaii International Conference on System Sciences, Island of Maui.
- [2] K. Maraiya, K. Kant, and N. Gupta, 2011, Application-based Study on Wireless Sensor Network, International Journal on Computer Applications, 21(8):9-15.
- [3] Stefanos A. Nikolidakis, Dionisis Kandris, and Dimitrios D. Vergados, 2013, Energy Efficient Routing in Wireless Sensor Networks Through Balanced Clustering, Article on Algorithms, Vol.6: 29-42.
- [4] Wan Norsyafizan W.Muhamad, Kaharudin Dimiyati, Roslina Mohamad, 2010, Evaluation of Stable Cluster Head Election (SCHE) Routing Protocol for Wireless Sensor Networks, International Multiconference of Engineers and Computer Scientist, Vol.2 Hong Kong.
- [5] S.K. Singh, M.P. Singh, and D.K. Singh, 2010, A Survey of Energy-Efficient Hierarchical Cluster-Based Routing in Wireless Sensor Networks, International Journal of Advanced Networking and Applications, 2(2):570-580.
- [6] S.K. Singh, M.P. Singh, and D.K. Singh, 2010, Energy-efficient Homogeneous Clustering Algorithm for Wireless Sensor Network, International Journal of Wireless & Mobile Networks, 2(3):49-61.
- [7] G.z.Zheng, S.Y.Liu, and X.G.Qi, 2012, Clustering routing algorithm of wireless sensor networks based on the Bayesian game, Journal of systems engineering and electronics, Vol.1:154.
- [8] Srie Vidhya Janani E, Ganeshkumar.P, Vasantha Suganthi.G, Sultan.M, and Kaleeswaran. D, 2013, A Survey on Algorithms for Cluster Head Selection in WSN, International Journal of Advanced Research in Computer Engineering & Technology, 2(5).
- [9] Qian Liao, Hao Zhu, 2013, An Energy-Balanced Clustering Algorithm Based on LEACH Protocol, Proceedings of the 2<sup>nd</sup> International Conference on Systems Engineering and Modeling.
- [10] Dilip Kumar Trilok, C. Aseri and R. B. Patel, 2011, A Novel Multihop Energy Efficient Heterogeneous Clustered Scheme for Wireless Sensor Networks, Tamkang Journal of Science and Engineering, 14(4):359-368.
- [11] L.A. Zadeh, 1965, Fuzzy Sets, Information and Control, 8(3):338-353.

- [12] L.A. Zadeh, 1968, Fuzzy Algorithms, *Information and Control*, 12(2): 94-102.
- [13] T. Mitsuishi, N. Endou, and Y. Shidama, 2001, The concept of fuzzy set and membership function and basic properties of fuzzy set operation, *Formalized Mathematics*, 9(2):351-356.
- [14] Rogaia Mhemeda, Nauman Aslam, William Phillips, and Frank Comeaux, 2012, Energy Efficient Fuzzy Logic Cluster Formation Protocol in Wireless Sensor Networks, *Procedia Computer Science*, Vol.10:255-262.
- [15] Abbas Karimi, S. M. Abedini, Faraneh Zarafshan, and S.A. R Al-Haddad, 2013, Cluster Head Selection Using Fuzzy Logic and Chaotic Based Genetic Algorithm in Wireless Sensor Network, *Journal of Basic Applied Science Research*, 3(4):694-703.
- [16] S. Swapna Kumar, M. Nanda Kumar, V. S. Sheeba, and K. R. Kashwan, 2012, Cluster-Based Routing Algorithm Using Dual Staged Fuzzy Logic in Wireless Sensor Networks, *Journal of Information & Computational Science* 9(5):1281–1297.
- [17] A.M Nirmala, P.Subramaniam, A. Anusha Priya and M. Ravi, 2013, Enriched Performance on Wireless Sensor Network using Fuzzy based Clustering Technique, *International Journal of Computer Science*, 2(3):11-15.
- [18] Zhang, Ying; Wang, Jun; Han, Dezhi; Wu, Huafeng; Zhou, Rundong. 2017, “Fuzzy-Logic Based Distributed Energy-Efficient Clustering Algorithm for Wireless Sensor Networks” *Sensors* 17, no. 7: 1554.